

### 1 - HEIGHT ADJUSTMENT LEVER

#### To raise

With the right hand, pull lever up while taking your weight off chair

—

#### To lower

With the right hand, pull lever up while seated



### 2 - TILT LOCK / UNLOCK KNOB

#### To lock tilt recline

Bring the backrest to the desired position using your body weight and, with the left hand, rotate knob forwards

—

#### To unlock tilt recline

With the left hand, rotate knob backwards and unlock the tilt using your body weight



### 3 - TENSION ADJUSTMENT KNOB

#### To increase

With the right hand, extract knob and rotate it forwards

—

#### To decrease

With the right hand, extract knob and rotate it backwards

#### PRODUCT NAME

**Core**

#### TYPE

**Synchro tilt mechanism**

#### FEATURES

**Height adjustment**

—

**Comfort adjustment**

—

**Tilt lock**

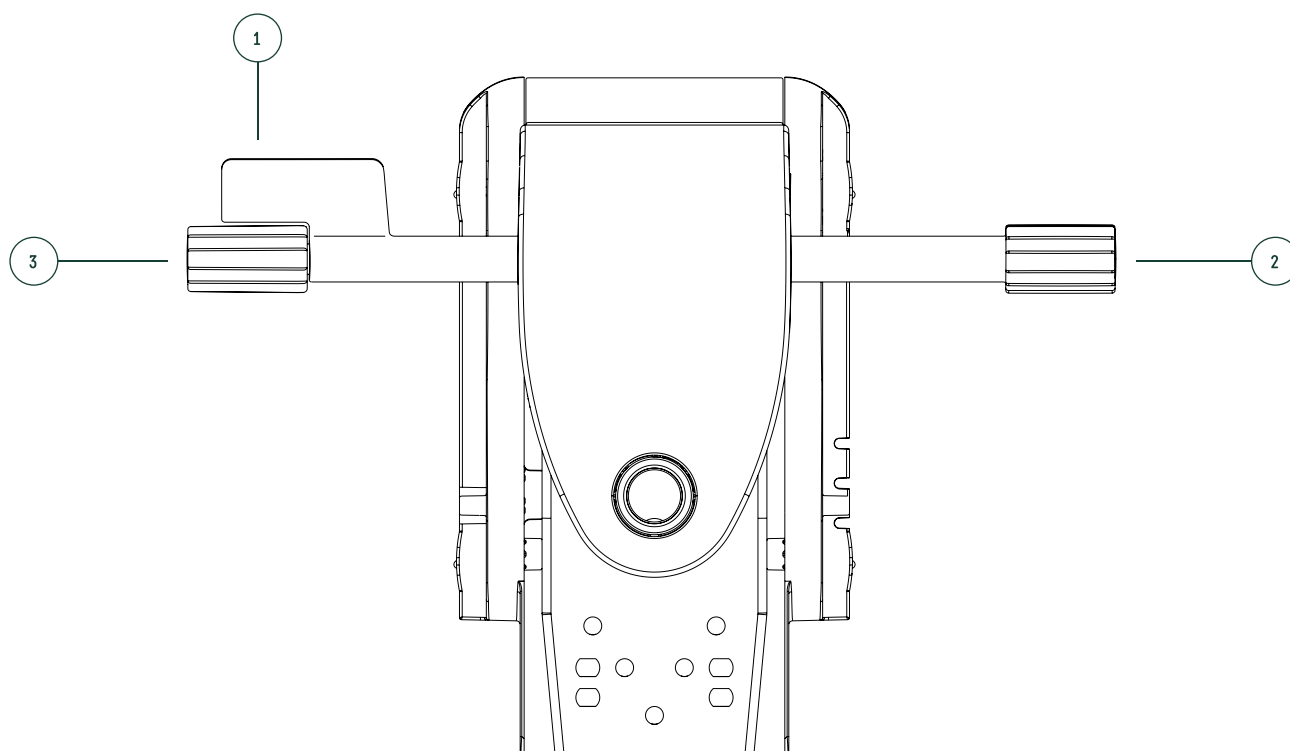

### 1 - HEIGHT ADJUSTMENT LEVER

#### To raise

With the right hand, pull lever up while taking your weight off chair

—

#### To lower

With the right hand, pull lever up while seated



### 2 - SEAT ANGLE ADJ. KNOB

#### To activate

With the left hand, push knob inwards

—

#### To deactivate

With the left hand, pull knob outwards



### 3 - TENSION ADJUSTMENT KNOB

#### To increase

With the right hand, extract knob and rotate it forwards

—

#### To decrease

With the right hand, extract knob and rotate it backwards

#### PRODUCT NAME

**Core Seat angle adjustment**

#### TYPE

**Synchro tilt mechanism**

#### FEATURES

**Height adjustment**

—

**Comfort adjustment**

—

**Seat angle adjustment**