

SPECIFICATIONS	
TYPE	Gas spring
EXTERNAL DIAMETER	50,0 mm [1.97 in]
INSIDE GAS LIFT DIAMETER	28,0 mm [1.10 in]
CLASS	3
FORCE	400N
GAS SPRING HEIGHT	252,0 / 386,0 mm [9.92 / 15.20 in]
STROKE	134,0 mm [5.28 in]
EXT. TAPER HEIGHT (∅ 50 mm)	– 70,0 mm [2.76 in] (TGS 210 - NE/CR) – 105,0 mm [4.13 in] (TGS 210 - NC/CC) – 155,0 mm [6.10 in] (TGS 210 - NX/XX)
INT. TAPER HEIGHT (∅ 28 mm)	219,0 mm [8.62 in]
GAS SPRING SURFACE FINISH	– Chrome – Black
ITEMS PER BOX (MOQ)	20 / 600

PRODUCT CODES

.....	
<u>TGS 210 - NE/CR</u>	
BLACK (NE)	4500087
CHROME (CR)	4500088
<u>TGS 210 - NC/CC</u>	
BLACK (NE)	4500089
CHROME (CR)	4500093
<u>TGS 210 - NX/XX</u>	
BLACK (NX)	4500084
CHROME (XX)	4500086

TECHNICAL DRAWING

TGS 210 - NE/CR GAS SPRING

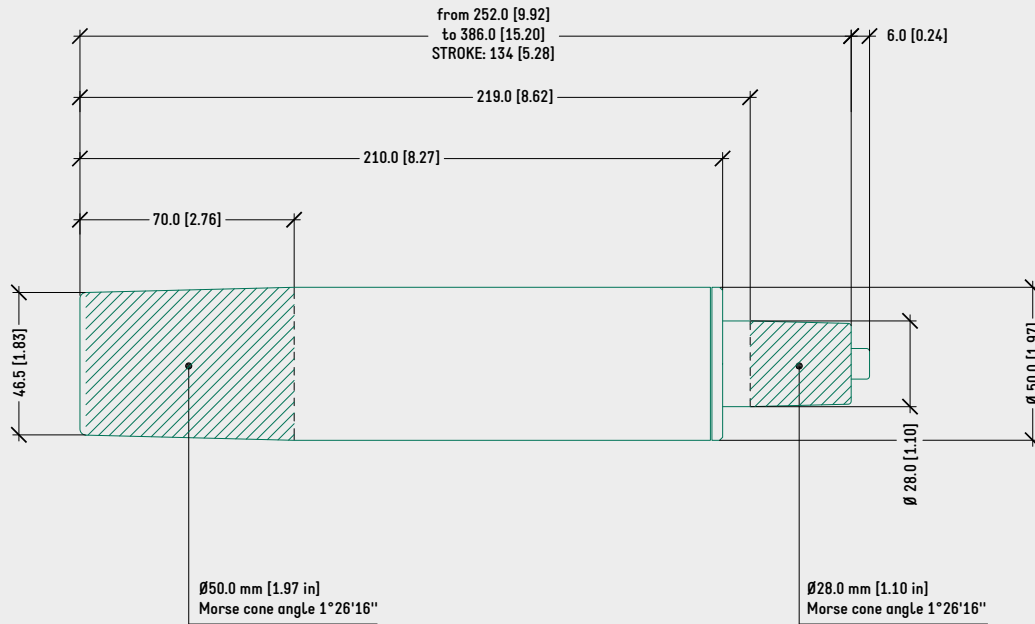

SURFACE COLOURS / FINISHES

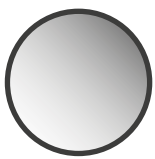

CHROME STEEL  
GAS SPRING



BLACK PAINTED  
GAS SPRING

TECHNICAL DRAWING

TGS 210 - NC/CC GAS SPRING

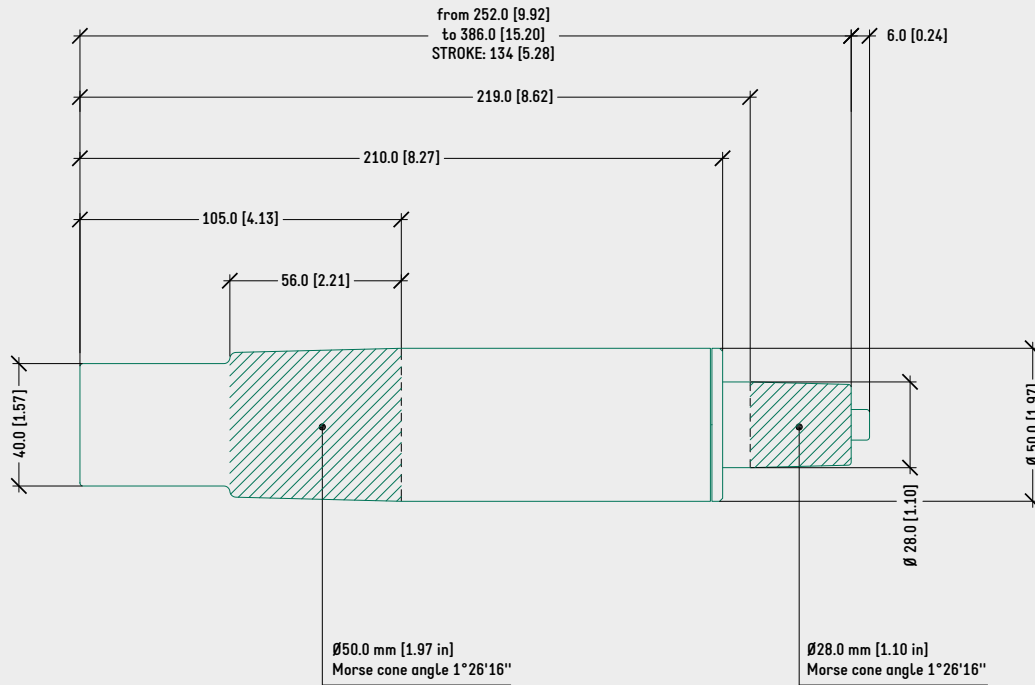

SURFACE COLOURS / FINISHES

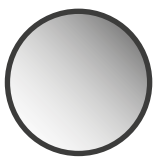

CHROME STEEL  
GAS SPRING



BLACK PAINTED  
GAS SPRING

TECHNICAL DRAWING

TGS 210 - NX/XX GAS SPRING

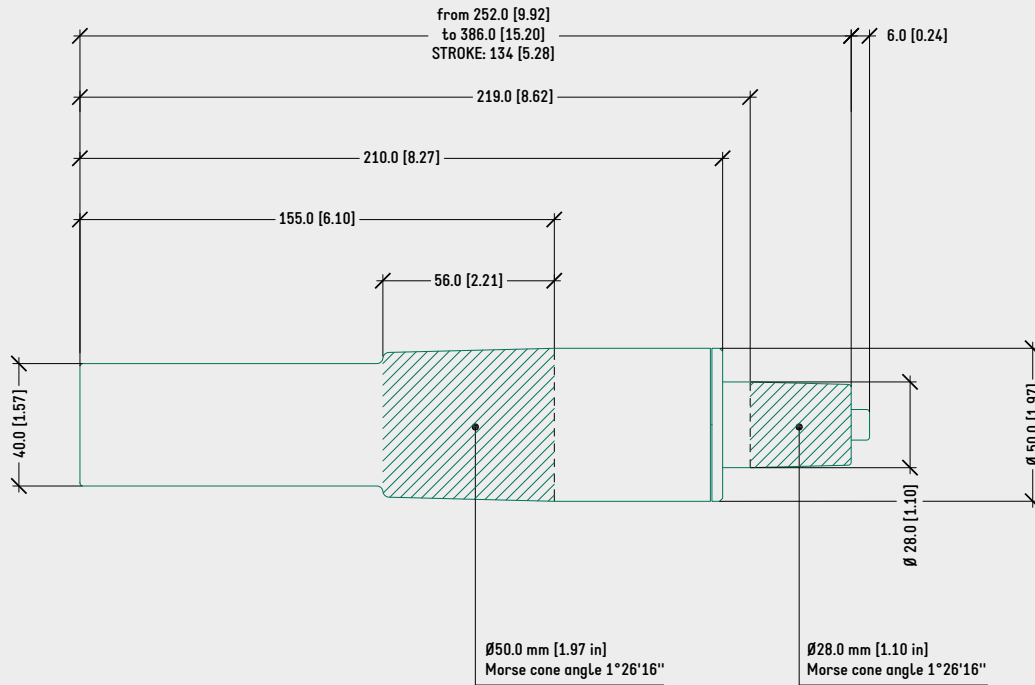

SURFACE COLOURS / FINISHES

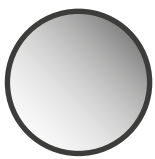

CHROME STEEL  
GAS SPRING



BLACK PAINTED  
GAS SPRING